

Supplemental Instructions for Extended Height Doors

This is a supplement to the **Residential Garage Door Instructions** (referred to as the MANUAL). Due to the size and weight of Extended Height residential garage doors, the installation procedure differs slightly from that of standard residential doors.

This supplement covers the following:

- Section Stacking
- Assembling and Installing Track
- Strut Requirements
- Bottom Bracket Installation
- Torsion Spring Installation

Section Stacking

Extended Height doors have a different section stacking order than standard doors. Refer to the tables to the right to determine the proper section arrangement for your particular door. Do NOT use Table 9-A in the MANUAL.

Assembling and Installing the Track

The track used for Extended Height doors is generally made of heavier gauge steel and attached with more track brackets than a standard door. 15" radius track is standard.

Numbered track brackets are installed on each side of the track starting 10" from the bottom, and sequentially every 24" from there up, with a maximum distance of 30" from the topmost track bracket to the flag bracket. (FIG. EH-1).

Follow the procedure described in the MANUAL for mounting the vertical track to the jambs and installing the horizontal track.

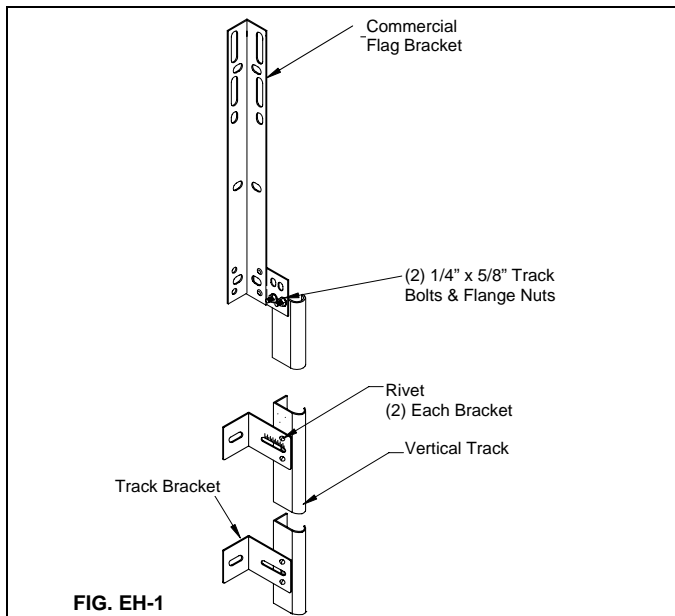

FIG. EH-1

IMPORTANT: Rear Track Hangers Requirements

Important Note: All doors over 12' high require two rear track hangers evenly spaced on each horizontal track. Also, all low headroom track doors, all doors 12' high and under that are over 600 lbs. or have 1" of sag in horizontal track when the door is in full open position, will require two rear track hangers evenly spaced on each horizontal track.

Stacking Order for Doors with 18" and 21" Section Heights

Door Height		Section Height									
Ft.	In.	A	B	C	D	E	F	G	H	I	J
8	3	21	21	18	18	21	-	-	-	-	-
8	6	21	21	21	18	21	-	-	-	-	-
8	9	21	21	21	21	21	-	-	-	-	-
9	0	18	18	18	18	18	18	-	-	-	-
9	3	18	18	18	18	18	21	-	-	-	-
9	6	21	18	18	18	18	21	-	-	-	-
9	9	21	21	18	18	18	21	-	-	-	-
10	0	21	21	21	18	18	21	-	-	-	-
10	3	21	21	21	21	18	21	-	-	-	-
10	6	21	21	21	21	21	21	-	-	-	-
10	9	18	18	18	18	18	18	21	-	-	-
11	0	21	18	18	18	18	18	21	-	-	-
11	3	21	21	18	18	18	18	21	-	-	-
11	6	21	21	21	18	18	18	21	-	-	-
11	9	21	21	21	21	18	18	21	-	-	-
12	0	21	21	21	21	21	18	21	-	-	-
12	3	21	21	21	21	21	21	21	-	-	-
12	6	21	18	18	18	18	18	18	21	-	-
12	9	21	21	18	18	18	18	18	21	-	-
13	0	21	21	21	18	18	18	18	21	-	-
13	3	21	21	21	21	18	18	18	21	-	-
13	6	21	21	21	21	21	18	18	21	-	-
13	9	21	21	21	21	21	21	18	21	-	-
14	0	21	21	21	21	21	21	21	21	-	-
14	3	21	21	18	18	18	18	18	18	21	-
14	6	21	21	21	18	18	18	18	18	21	-
14	9	21	21	21	21	18	18	18	18	21	-
15	0	21	21	21	21	21	18	18	18	21	-
15	3	21	21	21	21	21	21	18	18	21	-
15	6	21	21	21	21	21	21	21	18	21	-
15	9	21	21	21	21	21	21	21	21	21	-
16	0	21	21	21	18	18	18	18	18	18	21

Stacking Order for Doors with 18", 21", and 24" Section Heights

Door Height		Section Height							
Ft.	In.	A	B	C	D	E	F	G	H
8	3	21	21	18	18	21	-	-	-
8	6	21	21	21	18	21	-	-	-
8	9	21	21	21	21	21	-	-	-
9	0	21	21	21	21	24	-	-	-
9	3	24	21	21	21	24	-	-	-
9	6	24	24	21	21	24	-	-	-
9	9	24	24	24	21	24	-	-	-
10	0	24	24	24	24	24	-	-	-
10	3	21	21	21	21	18	21	-	-
10	6	21	21	21	21	21	21	-	-
10	9	21	21	21	21	21	24	-	-
11	0	24	21	21	21	21	24	-	-
11	3	24	24	21	21	21	24	-	-
11	6	24	24	24	21	21	24	-	-
11	9	24	24	24	24	21	24	-	-
12	0	24	24	24	24	24	24	-	-
12	3	21	21	21	21	21	21	21	-
12	6	21	21	21	21	21	21	24	-
12	9	24	21	21	21	21	21	24	-
13	0	24	24	21	21	21	21	24	-
13	3	24	24	24	21	21	21	24	-
13	6	24	24	24	24	21	21	24	-
13	9	24	24	24	24	24	21	24	-
14	0	24	24	24	24	24	24	24	-
14	3	21	21	21	21	21	21	21	24
14	6	24	21	21	21	21	21	21	24
14	9	24	24	21	21	21	21	21	24
15	0	24	24	24	21	21	21	21	24
15	3	24	24	24	24	21	21	21	24
15	6	24	24	24	24	24	21	21	24
15	9	24	24	24	24	24	24	21	24
16	0	24	24	24	24	24	24	24	24

Strut Requirements

The configuration of struts required for Extended Height doors is different than for standard doors. If a single strut was supplied with the door, this strut should be installed on the top section of the door. If multiple struts were provided they should be installed so that they are evenly distributed across the height of the door. The method of attaching the strut(s) will follow the procedure described in the MANUAL. Table 7-A in the MANUAL should NOT be used to determine strut placement.

Torsion Spring Installation

Bearing Plates:

Extended Height doors using torsion springs are provided with commercial end and center bearing plates. Some doors require a center bearing plate and bearing for each spring. Additionally, auxiliary bearing supports may be necessary. Auxiliary bearings must be assembled to the shaft before the cable drums are attached. Refer to FIG. EH-3 and FIG. EH-4 on the following pages for details.

Torsion Shaft:

If the door was supplied with a hollow torsion tube, refer to the supplemental torsion spring instructions provided for information on attaching cable drums.

If a solid torsion shaft is to be used, the cable drums must be secured with set screws and a key. Some doors will use two equal length shafts attached with a keyed coupler. (FIG. EH-4)

Spring Winding:

Follow the procedure described in the supplemental torsion spring instructions for winding springs. The number of turns required will be shown on the hardware box label. Do NOT use the winding chart in the torsion spring instructions to determine the number of winds required.

NOTE: If a hollow torsion tube is being used, all set screws should be turned about 1-1/4" turns after making contact with the tube. If using a solid shaft, set screws should be turned no more than 1/2 turn after making contact.



WARNING

SPRING TENSION IS DANGEROUS.

A sudden release of the springs could result in severe injury. Proceed with caution, following these instructions carefully. Before winding any tension on springs, make sure the door is securely locked down with a clamp placed on the vertical track above a roller. Always use good quality, snug fitting, constant diameter, solid steel winding bars when winding or adjusting the springs. The winding bar must be inserted into the full depth of the hole in the winding cone. Keep a firm grip on the winding bars at all times. Use a sturdy ladder and stand to the side of the winding bars. Springs should stretch easily. Do not force as it could break the winding plug and cause injury.

If your door has a torsion spring assembly, you must make sure that the wood anchor pad is firmly attached to the garage wall. Failure to securely attach the anchor pad could allow the springs to violently pull away from the garage wall, and could result in severe injury and/or property damage. In no case should nails be used.

End Hinges

To match the taper of the track some numbered end hinges may repeat instead of increasing sequentially. For example, a 10' high door with five sections may have the #3 hinge repeat, in which case the door would be installed with the following hinge pattern (starting from the bottom): #1, #2, #3, #3, #4. Which and how many hinge numbers repeat depends on the door size and model. Hinges should always be installed so that the numbers are in increasing order starting from the bottom. Repeating hinge numbers should be located consecutive to each other.

Bottom Bracket Installation

Some Extended Height doors require the use of standard-duty or heavy-duty bottom brackets (light-duty brackets are shown in the MANUAL). Refer to the adjacent figure to determine the proper method of attachment for the type of brackets provided with your door (FIG. EH-2).

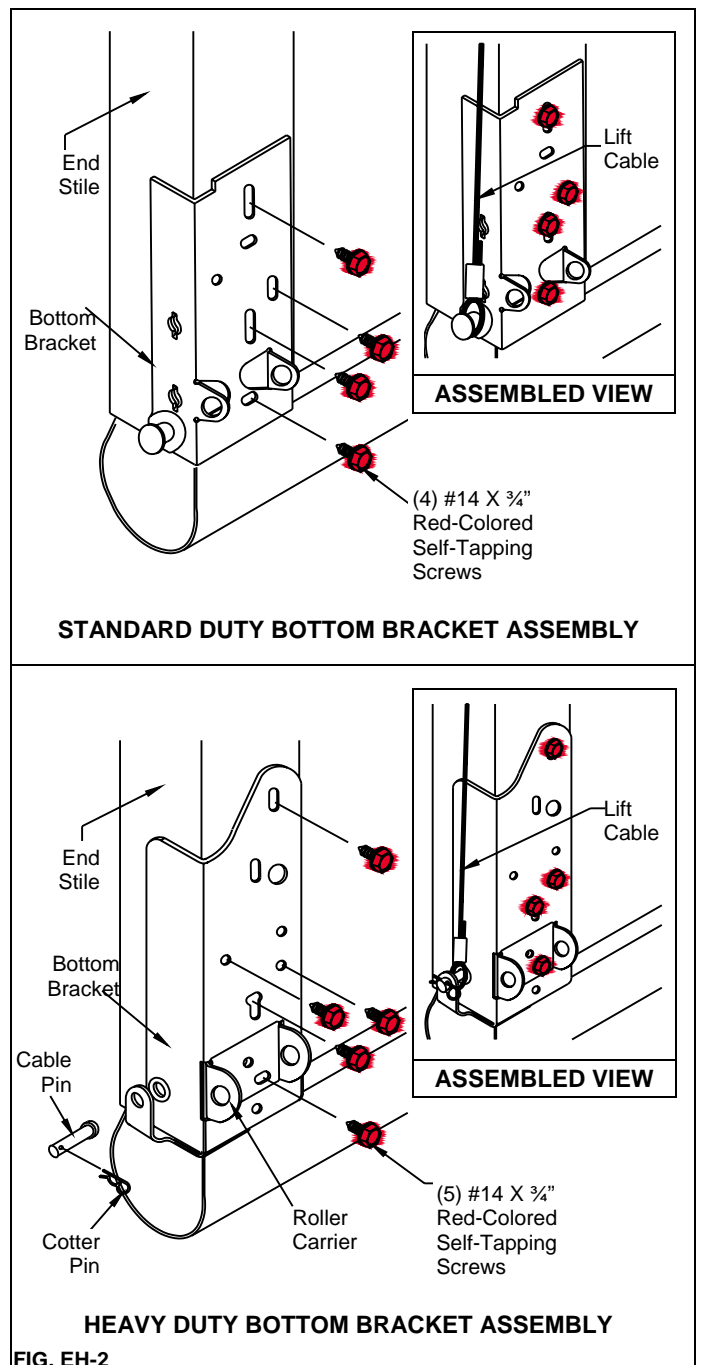
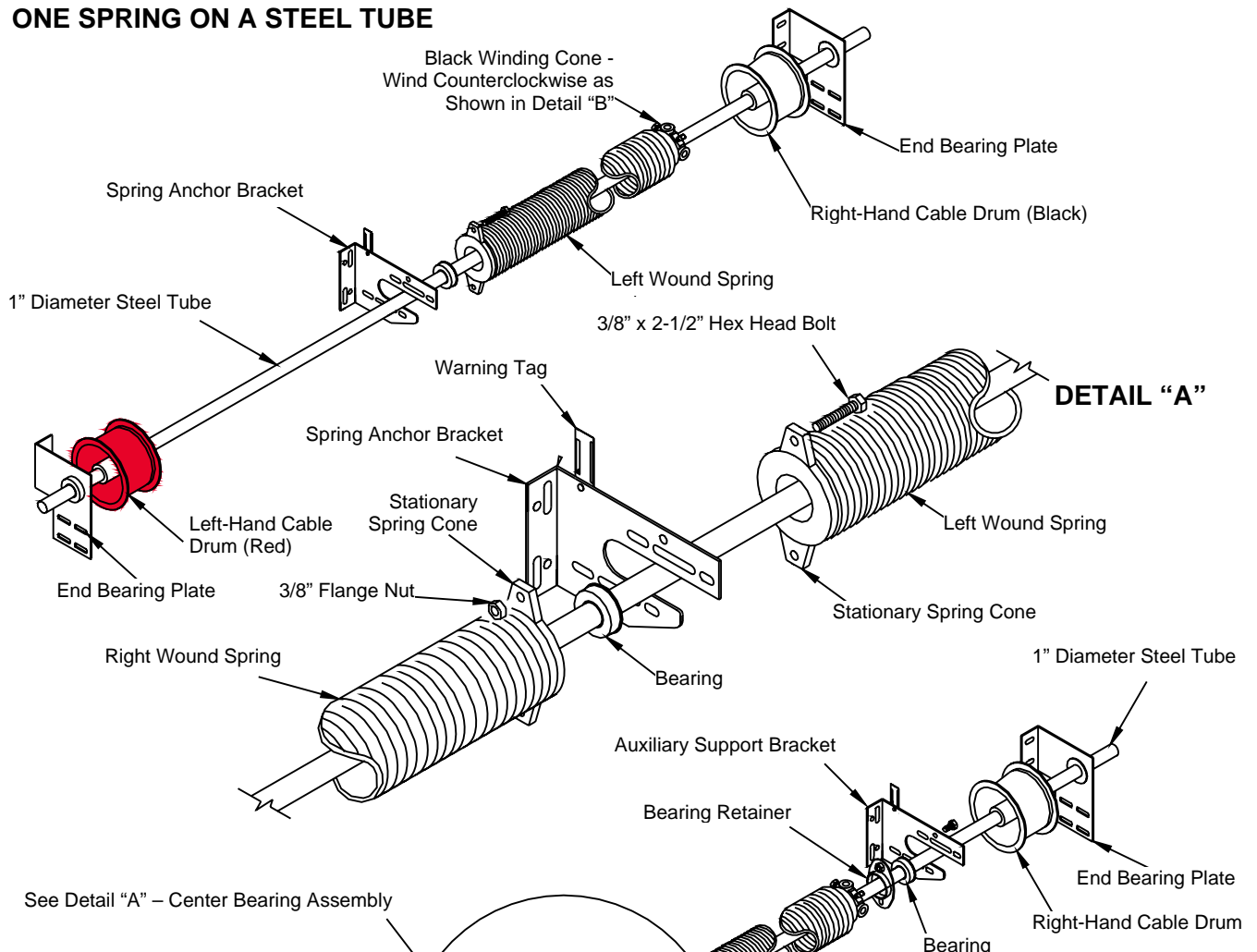

FIG. EH-2

ONE SPRING ON A STEEL TUBE



TWO SPRINGS ON A STEEL TUBE

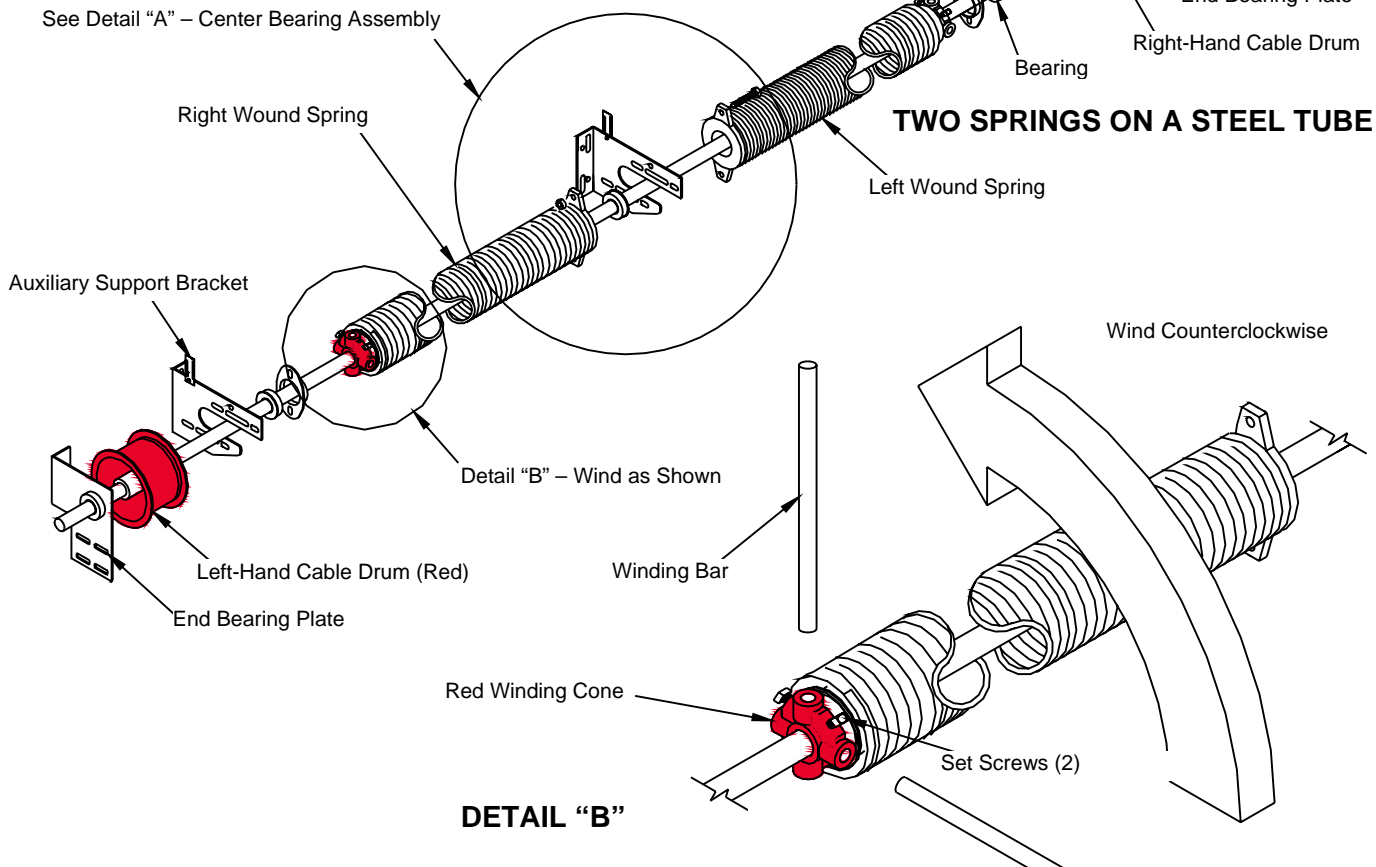
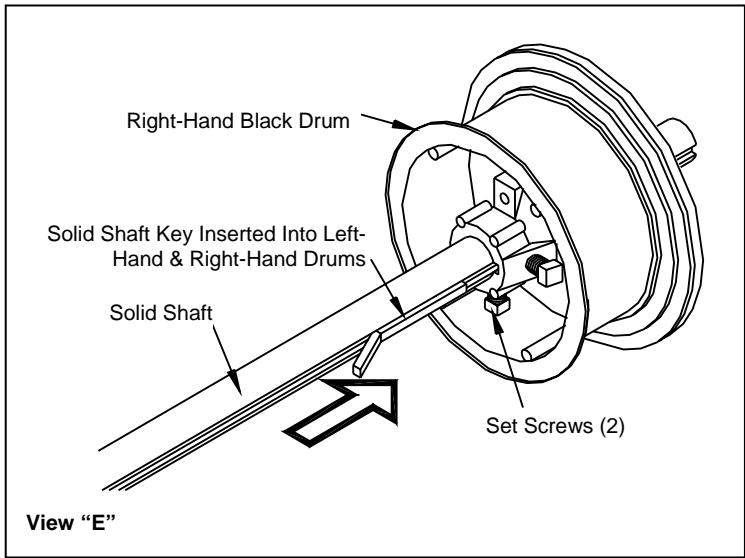

FIG EH-3



TWO SPRINGS ON A SOLID SHAFT

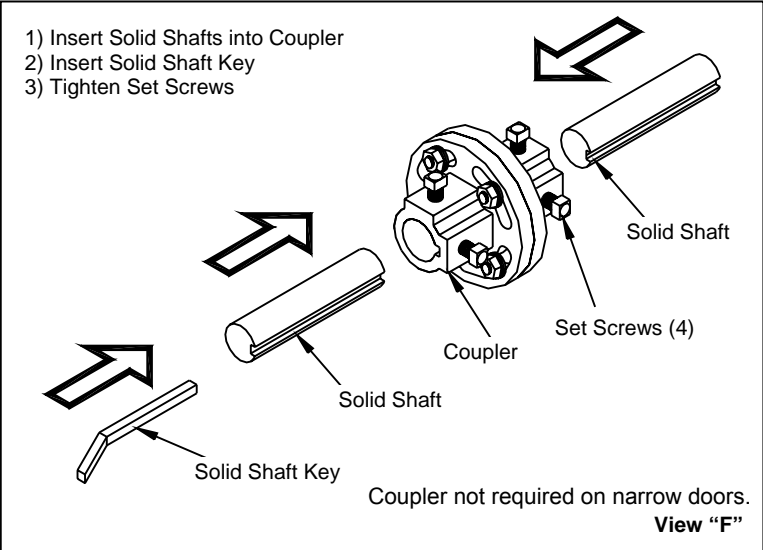
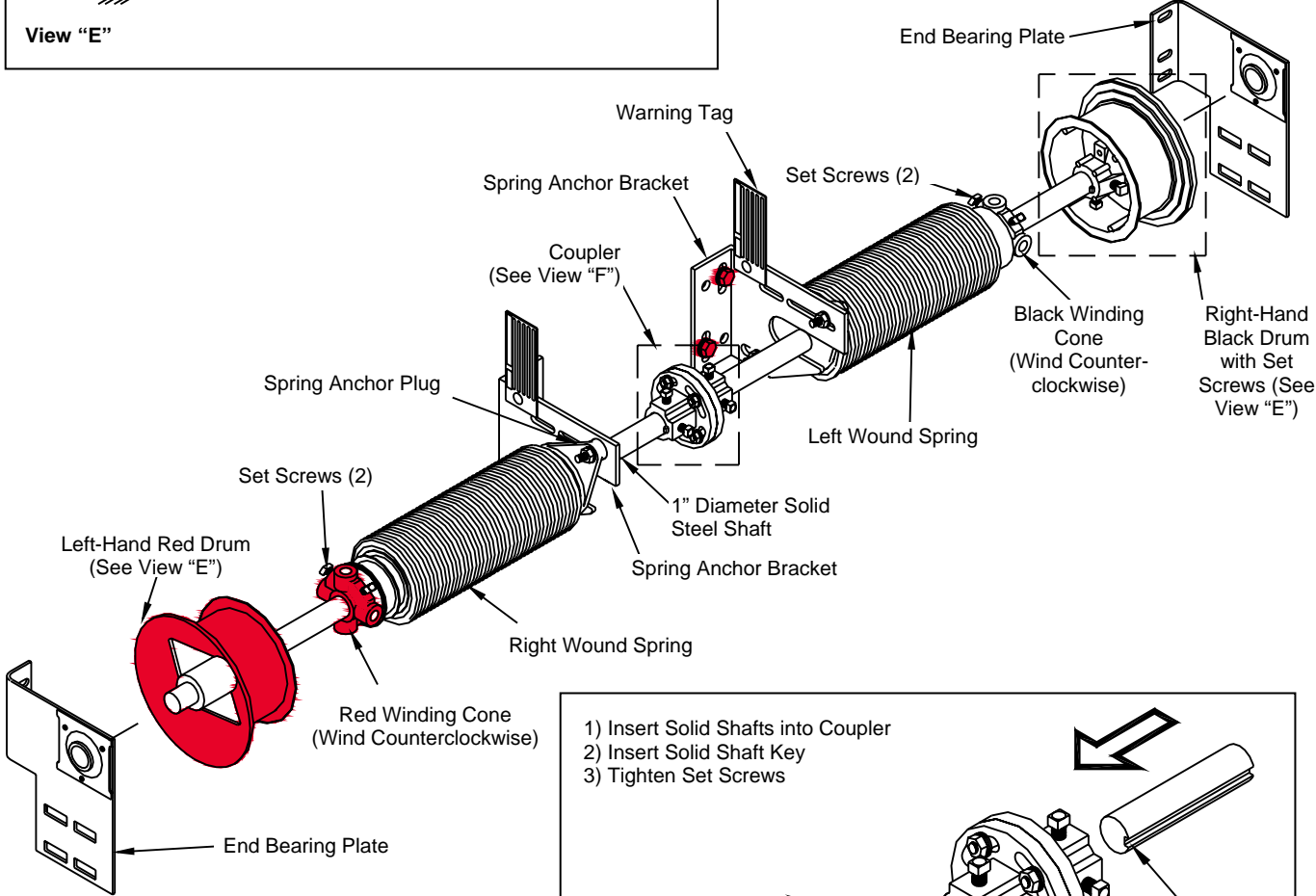

FIG. EH-4