INSTALLATION INSTRUCTIONS

Pan Adapter Rail Installation Supplemental Instructions

(For use with Commercial & Industrial Sectional Doors Installation & Maintenance Manual)

This is a supplement to the Commercial & Industrial Sectional Doors Installation & Maintenance Manual (Referred to as MANUAL). It covers important information unique to certain Commercial door configurations. For all other information and safety warnings concerning your Commercial garage door, see the MANUAL. Read all of the information in both manuals before beginning installation.

These instructions cover the following areas, where this Commercial door installation differs from the standard Commercial door installation:

1. Pan Adapter Rail Installation to the top of a Tongue and Groove Section
2. Pan Adapter Rail Installation to the Bottom of a Tongue and Groove Section

Pan Adapter Rail Installation to the Top of a Tongue and Groove Section

Step 1: Cut Rail. Cut rail to match the width of the door. If door width exceeds adapter rail length, two rails should be cut and placed end-to-end.

Step 2: Attach Rail. Screw Pan Adapter Rail to top of the Tongue and Groove section using #8-18 x 1" Tek screws so that fronts of rails, skins and sides are flush. Position the Tek screws approx. 24" apart across entire width of door section. (Fig 1)

Step 3: Attach Hinges. Place Spacer Plate between lower leaf of the hinge and the Tongue and Groove section. Attach using standard hardware used to attach hinges as described in the MANUAL.

Step 4: Finish Installation. Complete door installation as described in the MANUAL.

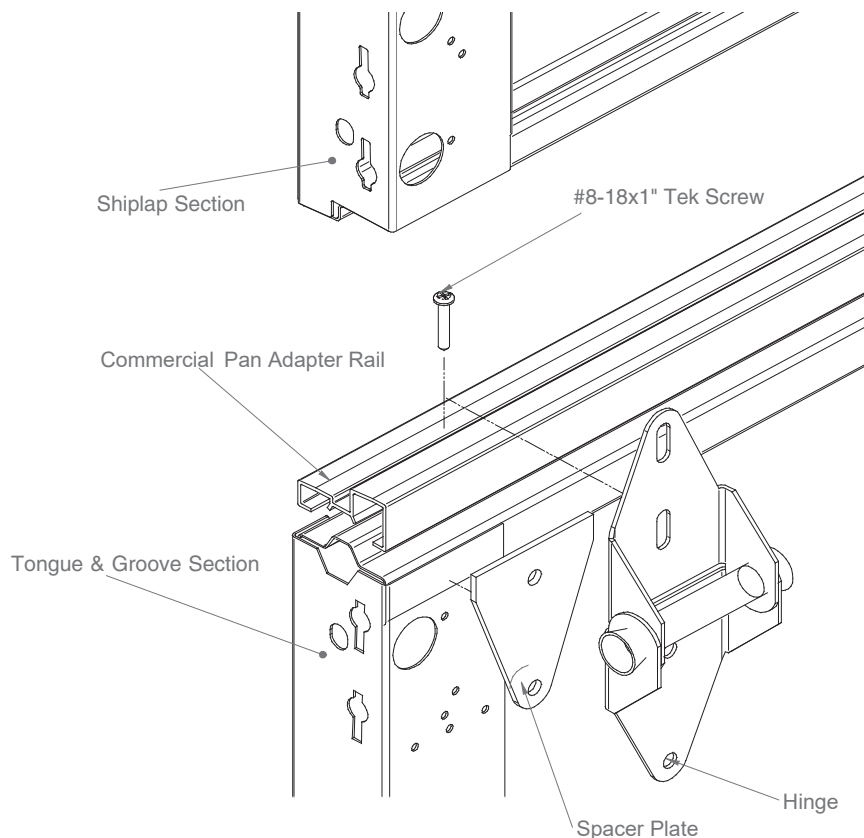

FIGURE 1

Pan Adapter Rail Installation to the Bottom of a Tongue and Groove Section

Step 1: Cut Rail. Cut rail to match the width of the door. If door width exceeds adapter rail length, two rails should be cut and placed end-to-end.

Step 2: Attach Rail. Screw Pan Adapter Rail to bottom of the Tongue and Groove section using #8-18 x 1" Tek screws so that fronts of rails, skins and sides are flush. Position the Tek screws approx. 24" apart across entire width of door section. (Fig 2)

Step 3: Attach Hinges. Place Spacer Plate between lower leaf of the hinge and the Tongue and Groove section. Attach using standard hardware used to attach hinges as described in the MANUAL.

Step 4: Finish Installation. Complete door installation as described in the MANUAL

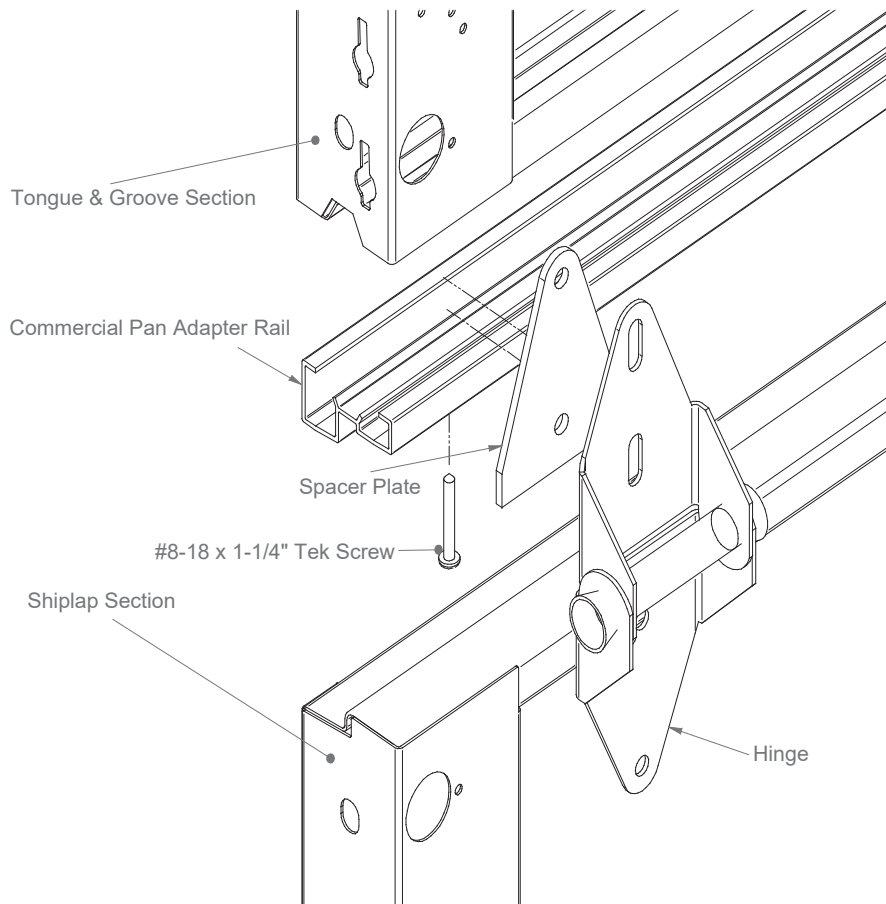

FIGURE 2