

Supplemental Instructions for High Lift Track

The general installation procedure for high lift track is similar to the procedure for installing standard lift track as outlined in Step 11 of the primary installation manual. The major differences for high lift track installation are outlined below.

Break-Away Style Track

Break-away style track consists of a two-section vertical portion – a bracket mounted lower track, and an angle mounted upper “break-away” track. The two sections of track are joined 8” below the top of the door with a special flag bracket (Fig. 1). The radius of the horizontal track is joined to the top of the break-away portion of the vertical track using the splice plate attached to the break-away angle (Fig. 2). All connections are made using 1/4” x 5/8” track bolts and 1/4” flange nuts.

Straight-Incline Style Track

Straight-incline track consists of a single piece vertical portion that is either bracket mounted or angle mounted depending on the door height restriction or option selected. Bracket mounted track uses the flag bracket shown in Fig. 1 to connect the vertical and horizontal track. If the track is angle mounted, the vertical and horizontal track will be connected using the splice plate shown in Fig. 2.

Additional Requirements for High Lift

All high lift configurations must have a spring bumper attached to the back of the horizontal track (Fig. 3). The spring bumpers and mounting brackets are packaged in the door’s hardware box.

A 21” long slotted angle is attached to the horizontal angle (Fig. 4) to serve as an extension to the vertical angle or flag bracket. Adjust as necessary to form a secure connection.

Some doors require special skip hinging patterns to allow for outside lift handle clearance. If this is the case then the end hinges provided with the door will not be numbered sequentially. End hinges should always be installed starting with the lowest numbered hinge at the bottom and continuing in increasing order ending with the highest numbered hinge at the top. Doors with skip hinging will also use a special adjustable top bracket (Fig. 5) that extends a greater distance from the door surface to the track.

Special Locking

Some doors require track that tapers away from the door at such an angle that a lock bar or slide lock will not engage into the standard lock slot in the track. In this situation, the lock bar will engage behind the track, underneath the nearest track clip as shown in Figure 6. If a preinstalled track clip is not located in a favorable location for your particular door setup, a pair of loose #14 track clips and fasteners that is provided in the hardware box. You will have to drill the holes in the vertical to attach the clips in the desired location.

Some doors are provided with a spacer for a side lock to allow it to engage the lock hole. To install place the spacer behind the lock and use the fasteners provided.

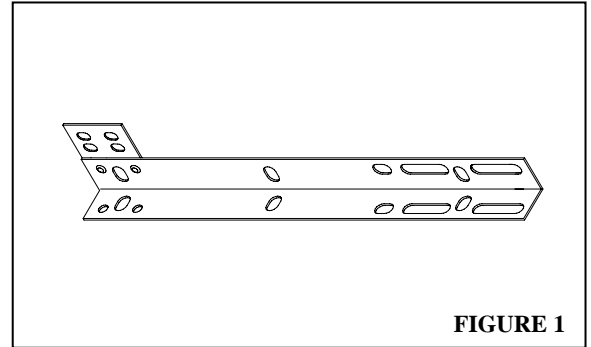

FIGURE 1

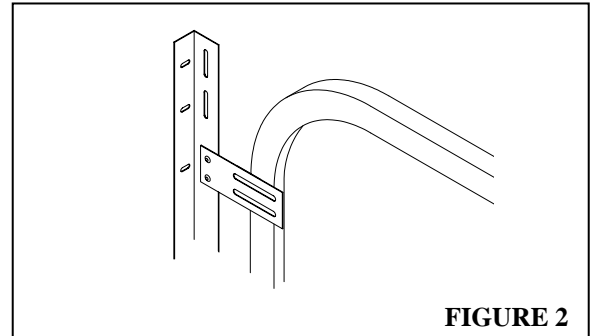

FIGURE 2

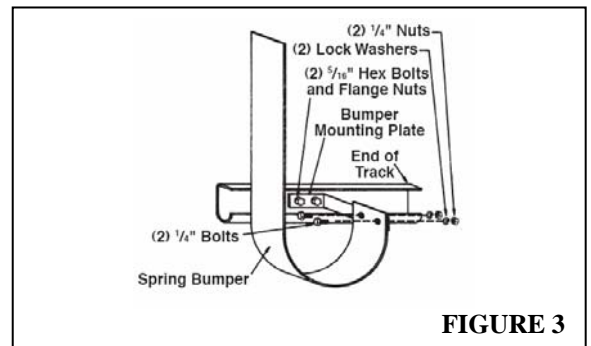

FIGURE 3

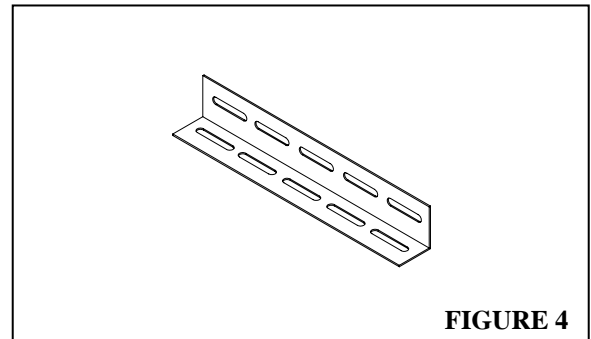

FIGURE 4

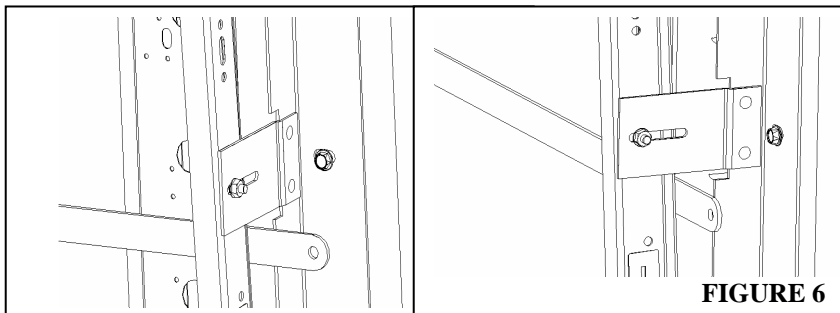

FIGURE 6

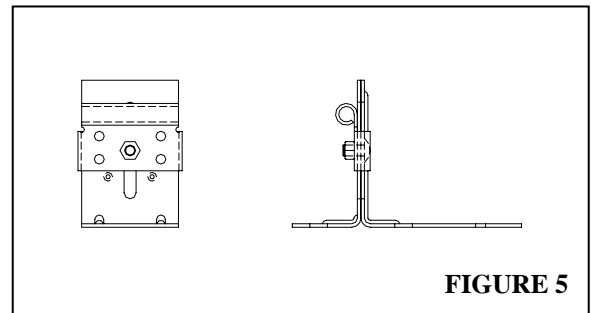
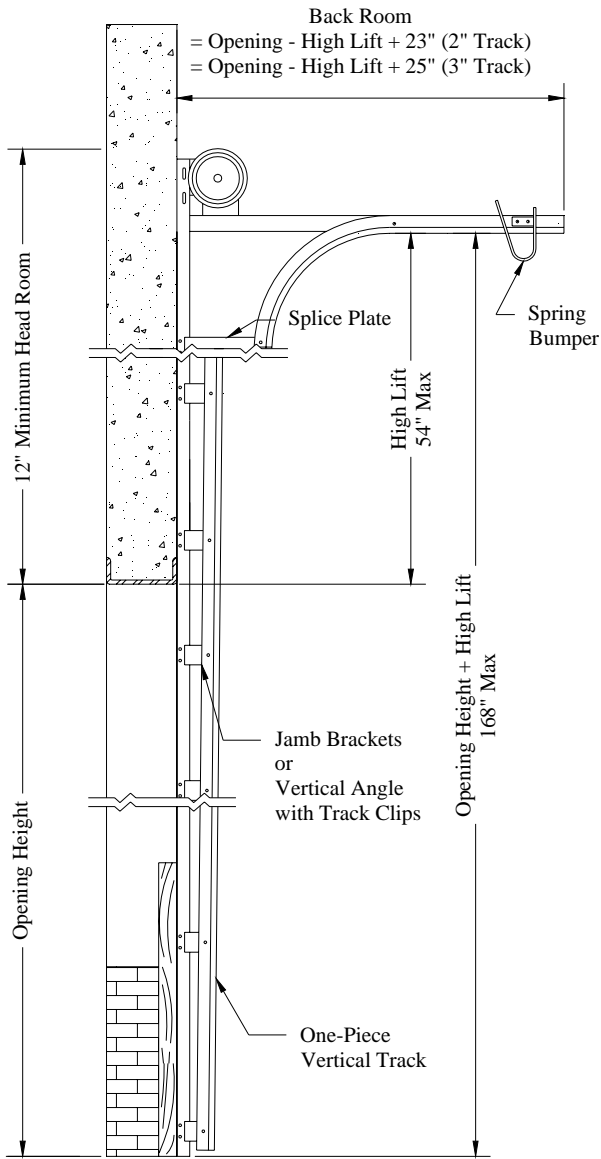

FIGURE 5

HIGH LIFT TRACK LAYOUT AND DIMENSIONS

HIGH LIFT STRAIGHT-INCLINE TRACK



HIGH LIFT BREAK-AWAY TRACK

